

UHMWPE pads on bunks

Rubber roller to support bow

Rubber vee snub block to hold nose of boat

Winch

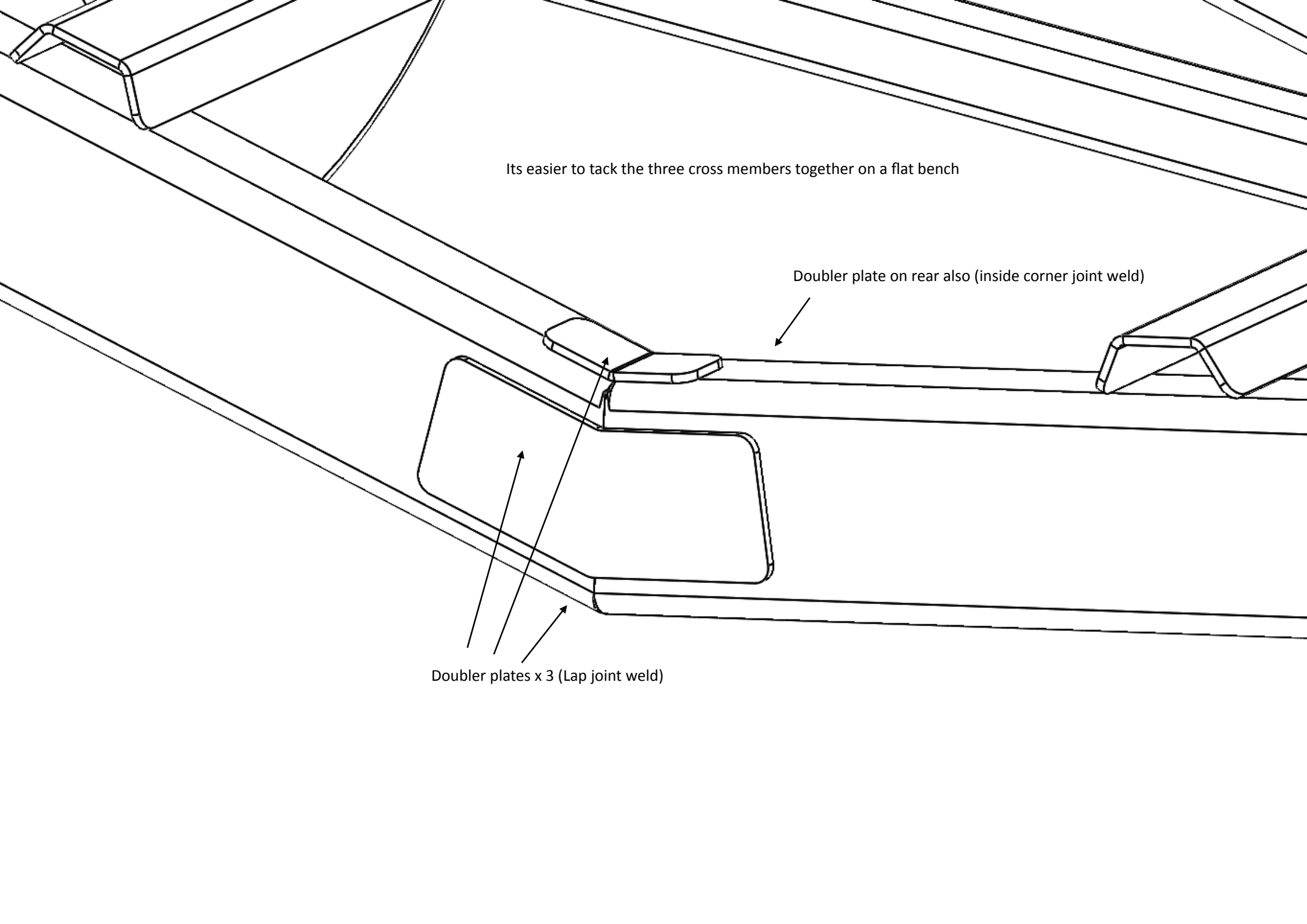

Its easier to tack the three cross members together on a flat bench

Doubler plate on rear also (inside corner joint weld)

Doubler plates x 3 (Lap joint weld)

Doubler plate on outside (lap joint weld)

Doubler plate on inside (inside corner joint weld)

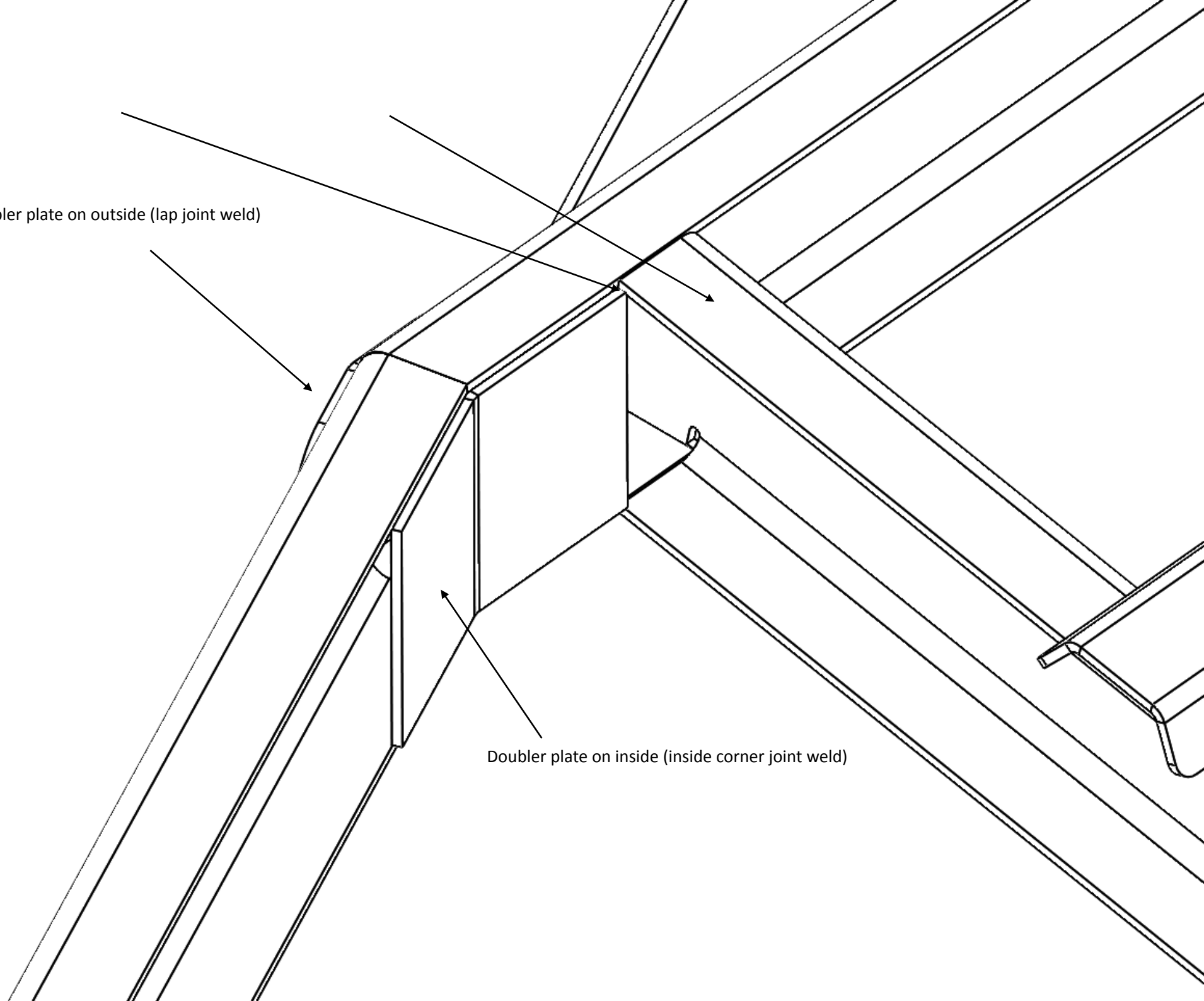

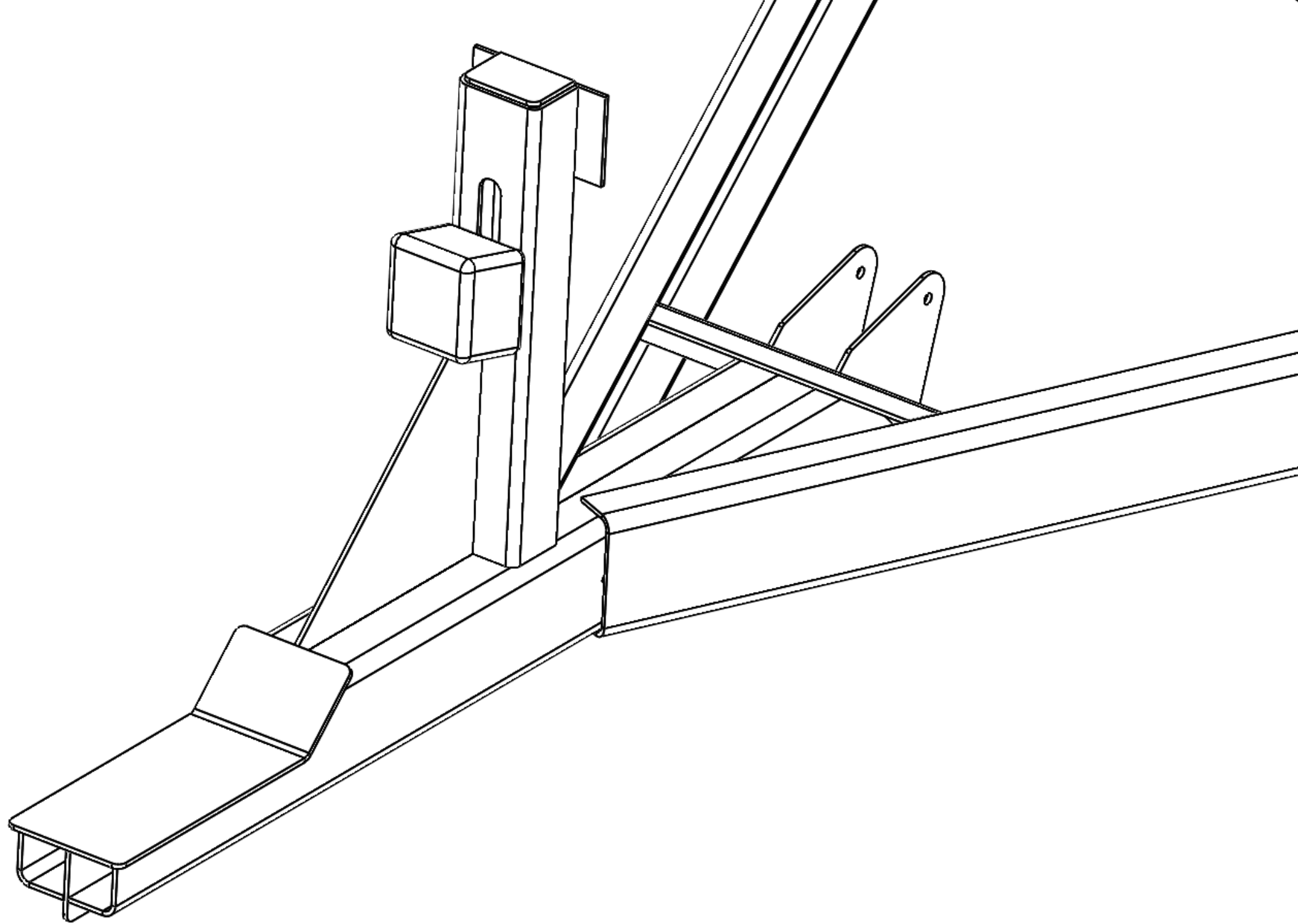

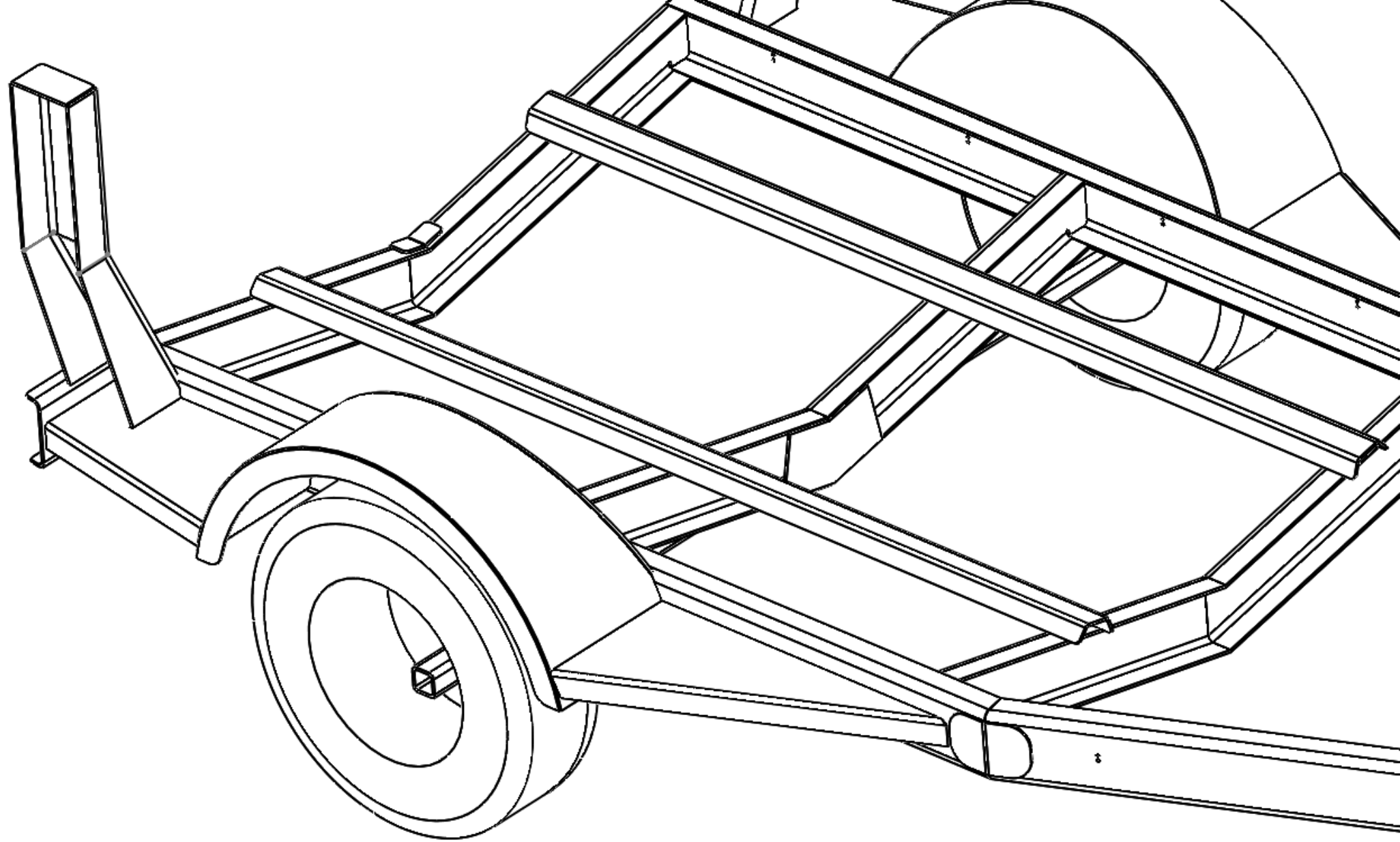

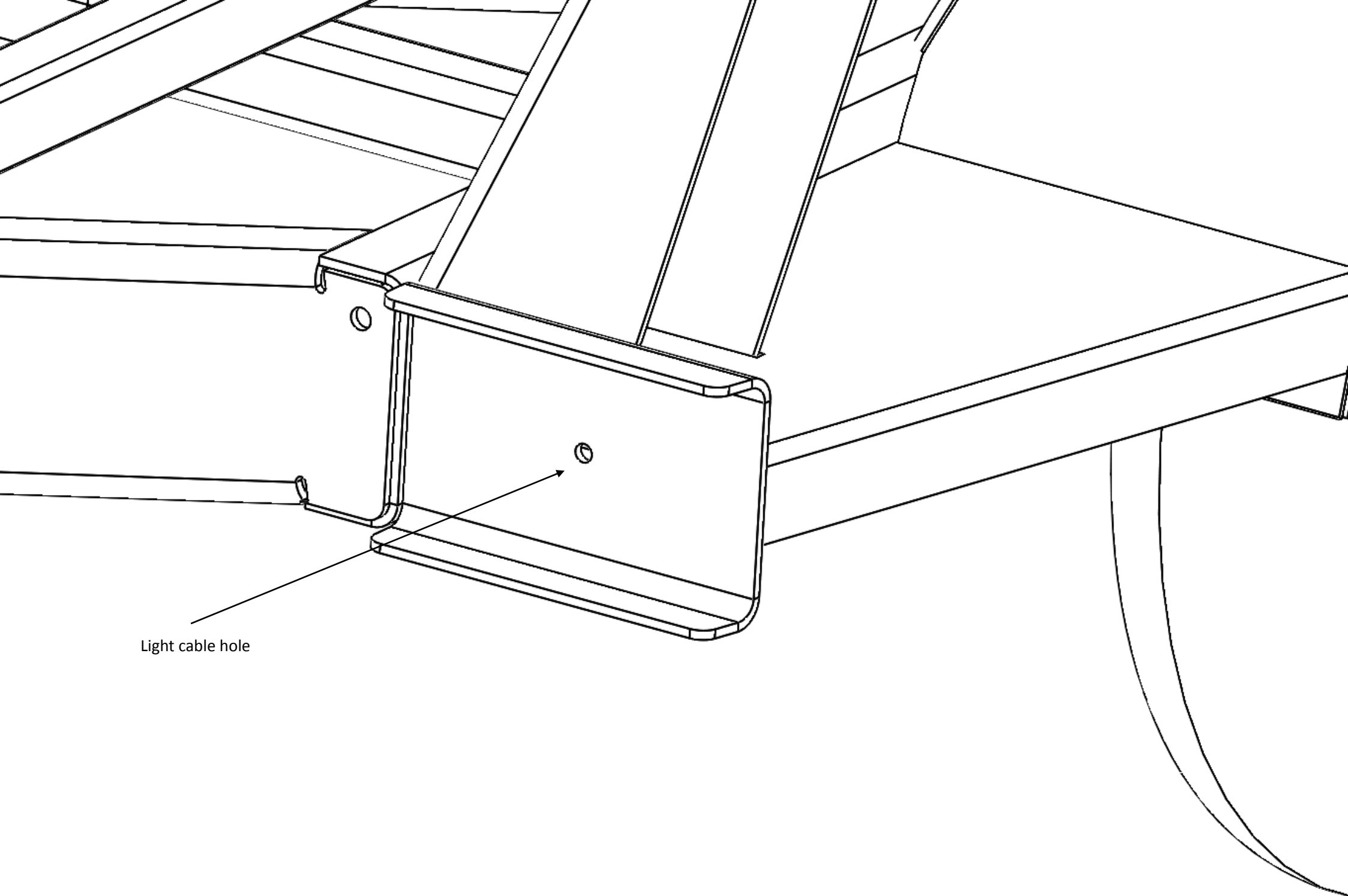

Light cable hole